



SCMN25 SERIES NANOCRYSTALLINE COMMON MODE CHOKE



ALL PARTS AVAILABLE AS CLASS S OR CLASS B

MIL-STD-981

Inductance Range (mH)	DCR max (Ohms)	Current Rating (A)
1.0 - 150	0.002 - 0.430	21.4 - 1.4

DIMENSIONS: INCHES (MM)
MARKINGS: LASER ETCH OR INK

ELECTRICAL SPECIFICATIONS

- **Operating Temperature:** -55°C to +125°C
- **Storage Temperature:** -60°C to +130°C
- **Temperature Rise @ 100°C:** < 30°C
- **Dielectric Withstanding Voltage:** 1000 V_{RMS}
- **Overload Current:** 1.5 times rated current
- **Different electrical values available upon request**

FEATURES

- **Terminations:** SnPb, Lead Free (RoHS)
- **Resistance to Soldering Heat:** 265°C for 10 seconds
- **Moisture, Shock and Immersion Resistant**
- **Magnetically Shielded**
- **Ideally designed for GaN applications and higher switching frequencies**
- **Designed with nanocrystalline core for superior thermal stability and higher frequency operations**
- **NASA outgassing compliant per ASTM E595 (TML <1%, CVCM <0.1%)**

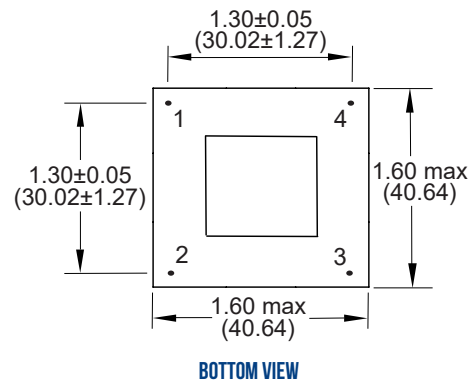
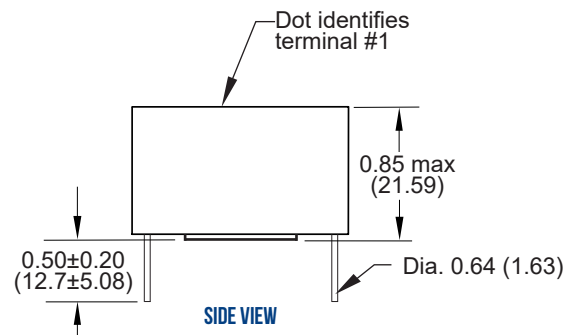
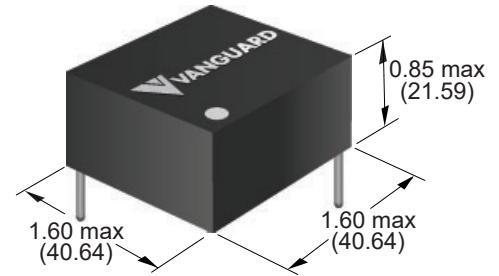

SCHEMATIC

CUSTOM DESIGNS & MODIFICATIONS:

Other electrical configurations and performance characteristics are available in various sizes and package types





DATA TABLE

Vanguard P/N	Inductance @ 10kHz ± 30% (mH)	DCR Max (Ohms)	Rated Current (A)
SCMN25-104TH	1.0	0.002	21.4
SCMN25-234TH	2.3	0.003	17.3
SCMN25-534TH	5.3	0.005	12.7
SCMN25-804TH	8.0	0.008	10.3
SCMN25-944TH	9.4	0.011	8.8
SCMN25-175TH	17	0.023	6.1
SCMN25-265TH	26	0.036	4.9
SCMN25-385TH	38	0.070	3.5
SCMN25-515TH	51	0.100	2.9
SCMN25-635TH	63	0.140	2.5
SCMN25-765TH	76	0.195	2.1
SCMN25-106TH	100	0.280	1.8
SCMN25-156TH	150	0.430	1.4

1/ Inductance measured at 10 kHz, 0.10 V_{RMS}

2/ DCR measured at room ambient temperature (25°C)

VE PART NUMBER STRUCTURE KEY

INDUCTANCE (uH) (mH)

234 = 2300 uH
265 = 26 mH
156 = 150 mH

EXAMPLE: SCMN25-234THS-3-B

TERMINATION

S	SnPb
R	Pure Tin

RELIABILITY

2	Group A MIL-STD-981
3	Group A+B MIL-STD-981
7	Other

PACKAGING (Default Bulk)

B	Bulk
---	------

CUSTOM DESIGNS & MODIFICATIONS:

Other electrical configurations and performance characteristics are available in various sizes and package types

SCMN25 SERIES

