



## SCMN30 SERIES NANOCRYSTALLINE COMMON MODE CHOKE



ALL PARTS AVAILABLE AS CLASS S OR CLASS B

MIL-STD-981

Inductance Range (mH)	DCR max (Ohms)	Current Rating (A)
0.9 - 200	0.0022 - 0.510	22.5 - 1.5

DIMENSIONS: INCHES (MM)  
MARKINGS: LASER ETCH OR INK

### ELECTRICAL SPECIFICATIONS

- **Operating Temperature:** -55°C to +125°C
- **Storage Temperature:** -60°C to +130°C
- **Temperature Rise @ 100°C:** < 30°C
- **Dielectric Withstanding Voltage:** 1000 V<sub>RMS</sub>
- **Overload Current:** 1.5 times rated current
- **Different electrical values available upon request**

### FEATURES

- **Terminations:** SnPb, Lead Free (RoHS)
- **Resistance to Soldering Heat:** 265°C for 10 seconds
- **Moisture, Shock and Immersion Resistant**
- **Magnetically Shielded**
- **Ideally designed for GaN applications and higher switching frequencies**
- **Designed with nanocrystalline core for superior thermal stability and higher frequency operations**
- **NASA outgassing compliant per ASTM E595** (TML <1%, CVCM <0.1%)

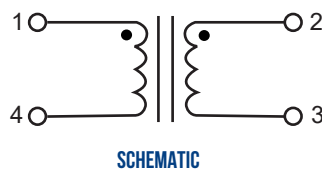
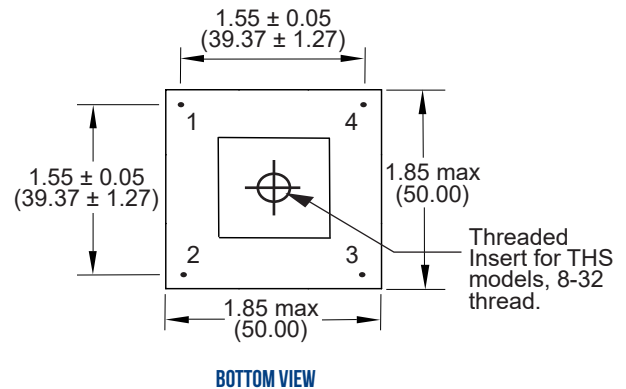
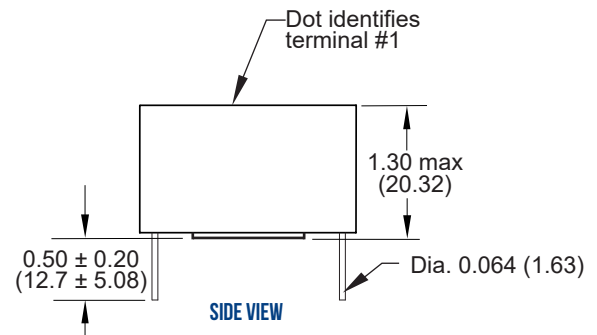
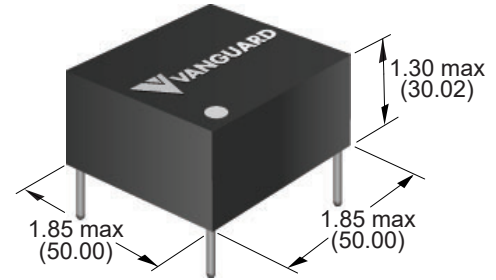

SCHEMATIC

## SCMN30 SERIES



### CUSTOM DESIGNS & MODIFICATIONS:

Other electrical configurations and performance characteristics are available in various sizes and package types





## DATA TABLE

Vanguard P/N	Inductance @ 10kHz ± 30% (mH)	DCR Max (Ohms)	Rated Current (A)
SCMN30-903TH	0.9	0.0022	22.5
SCMN30-274TH	2.7	0.004	16.9
SCMN30-554TH	5.5	0.006	14.2
SCMN30-804TH	8.0	0.008	11.6
SCMN30-125TH	12.5	0.011	9.9
SCMN30-255TH	25.0	0.028	6.2
SCMN30-505TH	50.0	0.064	4.2
SCMN30-755TH	75.0	0.100	3.3
SCMN30-106TH	100	0.145	2.8
SCMN30-156TH	150	0.280	2.0
SCMN30-206TH	200	0.510	1.5

1/ Inductance measured at 10 kHz, 0.10 V<sub>RMS</sub>

2/ DCR measured at room ambient temperature (25°C)

### VE PART NUMBER STRUCTURE KEY

#### INDUCTANCE (uH) (mH)

903 = 900 uH  
274 = 2.7 mH  
206 = 200 mH

### EXAMPLE: SCMN30-903THS-3-B

#### TERMINATION

S	SnPb
R	Pure Tin

#### RELIABILITY

2	Group A MIL-STD-981
3	Group A+B MIL-STD-981
7	Other

#### PACKAGING (Default Bulk)

B	Bulk
---	------

### CUSTOM DESIGNS & MODIFICATIONS:

Other electrical configurations and performance characteristics are available in various sizes and package types

## SCMN30 SERIES

